

Installation Instructions for Model 5152 Pedestal Base Assembly

Attaching 3M™ VHB™ Pads:

1. Wipe bottom of pedestal base with alcohol, acetone, or equivalent.
2. Sweep floor and wipe with alcohol, acetone, or equivalent.
3. Adhere VHB pads (4) to bottom of pedestal base as shown:

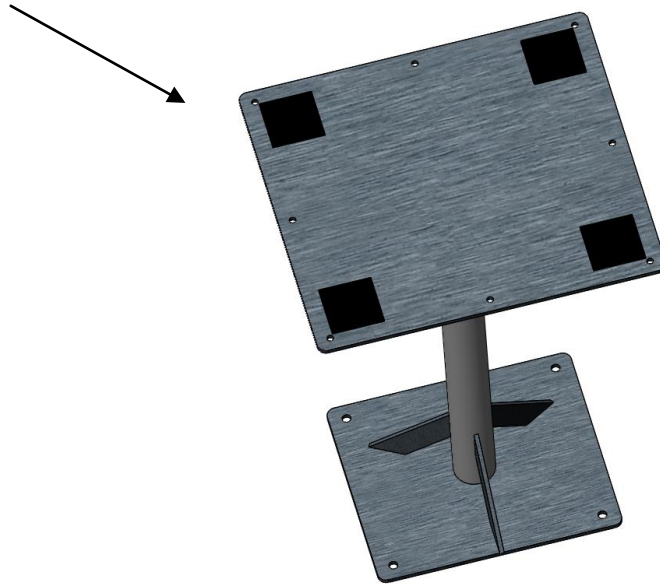

4. Place pedestal base on clean floor.

Attaching Machine to Base: (Tighten bolts equally so the machine is ½" from top plate)

1. Set rubber bumpers into place on the top plate of the base before placing machine.
2. Place machine.
3. Place washers on each of the 4 bolts and insert the four bolts through the top.
4. Attach the washer and nut.

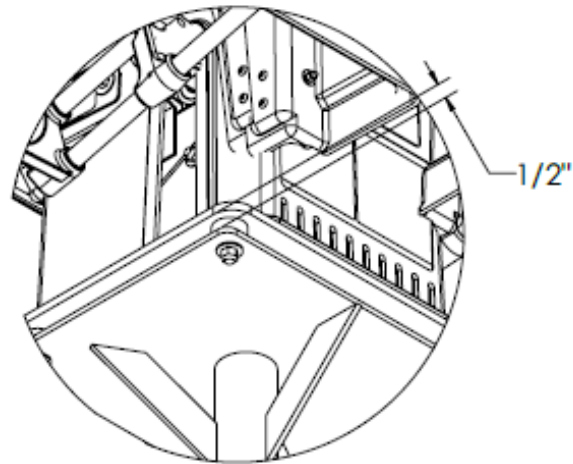

Moving Pedestal Base:

If it becomes necessary to move the machine to a different location, release the bond between the floor and pedestal base by inserting a wall scraper between them. Contact Red Devil Equipment Co. / Radia for replacement VHB pads.

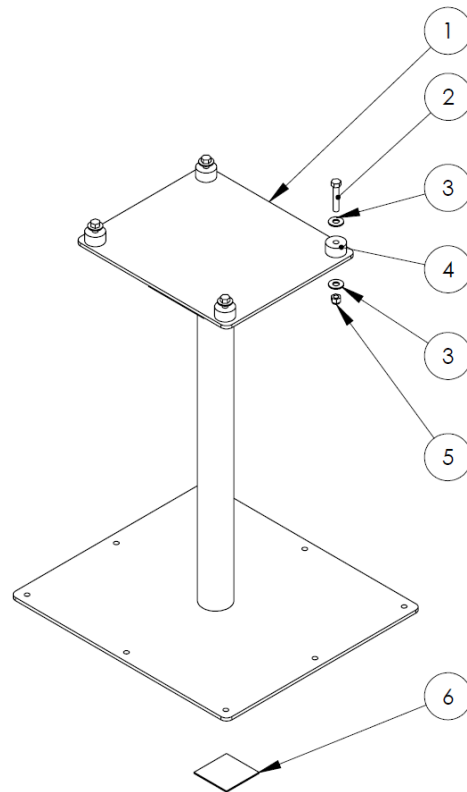

	Part No.	Description	Qty.
1	8577500	Base weldment	1
2	9780617	Screw, Hex 3/8-16 x 2.00	4
3	9161100	Washer, flat 3/8	8
4	9327500	Bumper, rubber	4
5	9780193	Nut, Nylock 3/8-16	4
6	6787670	Feet, 3M VHB Kit (4 Pads)	1